

SERIES INFORMATION
CANNED MOTOR PUMP TYPE CNF

REFRIGERATION ENGINEERING

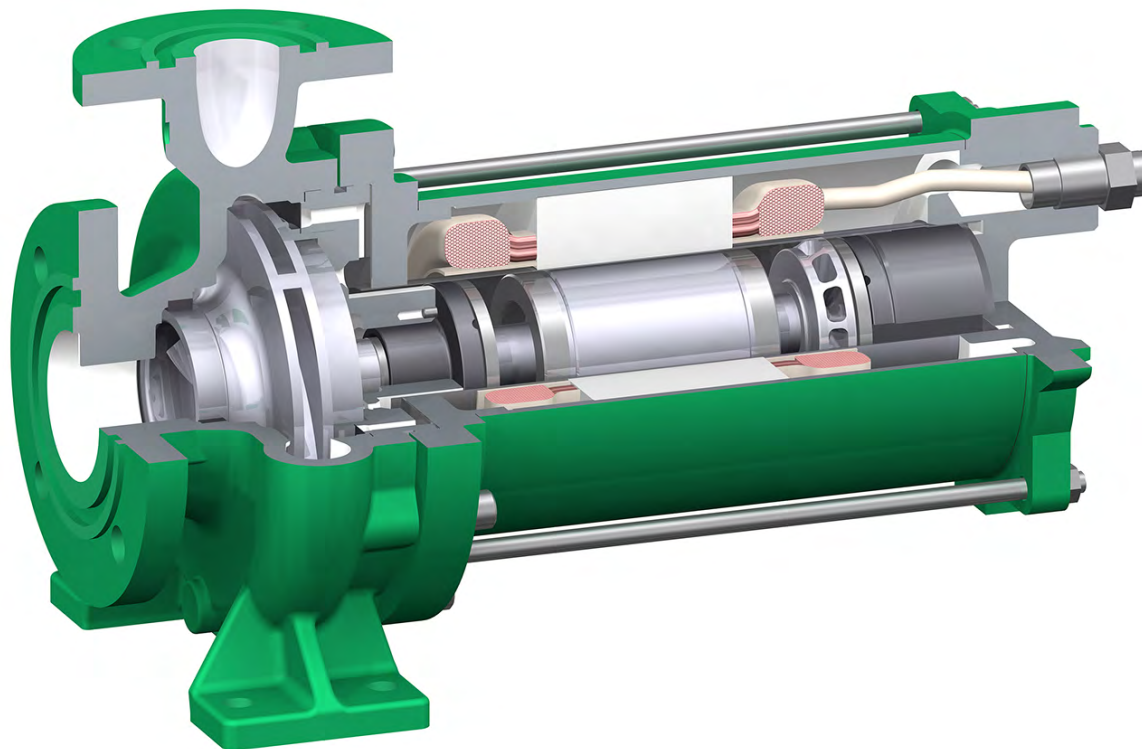

ZART®

simply best balance

Information

Operating data

Temperature

Application conditions	-50 °C to +30 °C
------------------------	------------------

Canned motors

Output	up to 15.7 kW
--------	---------------

Speed	2800 rpm or 3500 rpm (frequency control possible – from 1500 rpm to 3500 rpm)
-------	---

Voltage	230, 400, 480, 500, 575, 690 Volt
---------	-----------------------------------

Frequency	50 or 60 Hz
-----------	-------------

Type of protection	IP 55
--------------------	-------

Pump and hydraulics designations

CNF 40 – 160 AGX 3.0

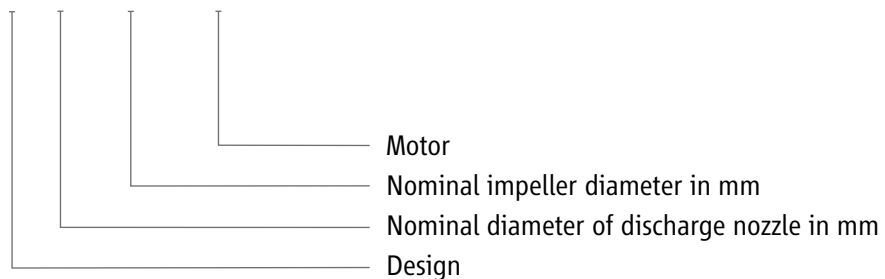

Table of Contents

General information

Function

Operating principle

Characteristic maps

Versions

List of parts

Collective measurements

Documentation and tests

Installation

Protection and monitoring

Flow regulation

Design software

Contact



2900 rpm 50 Hz

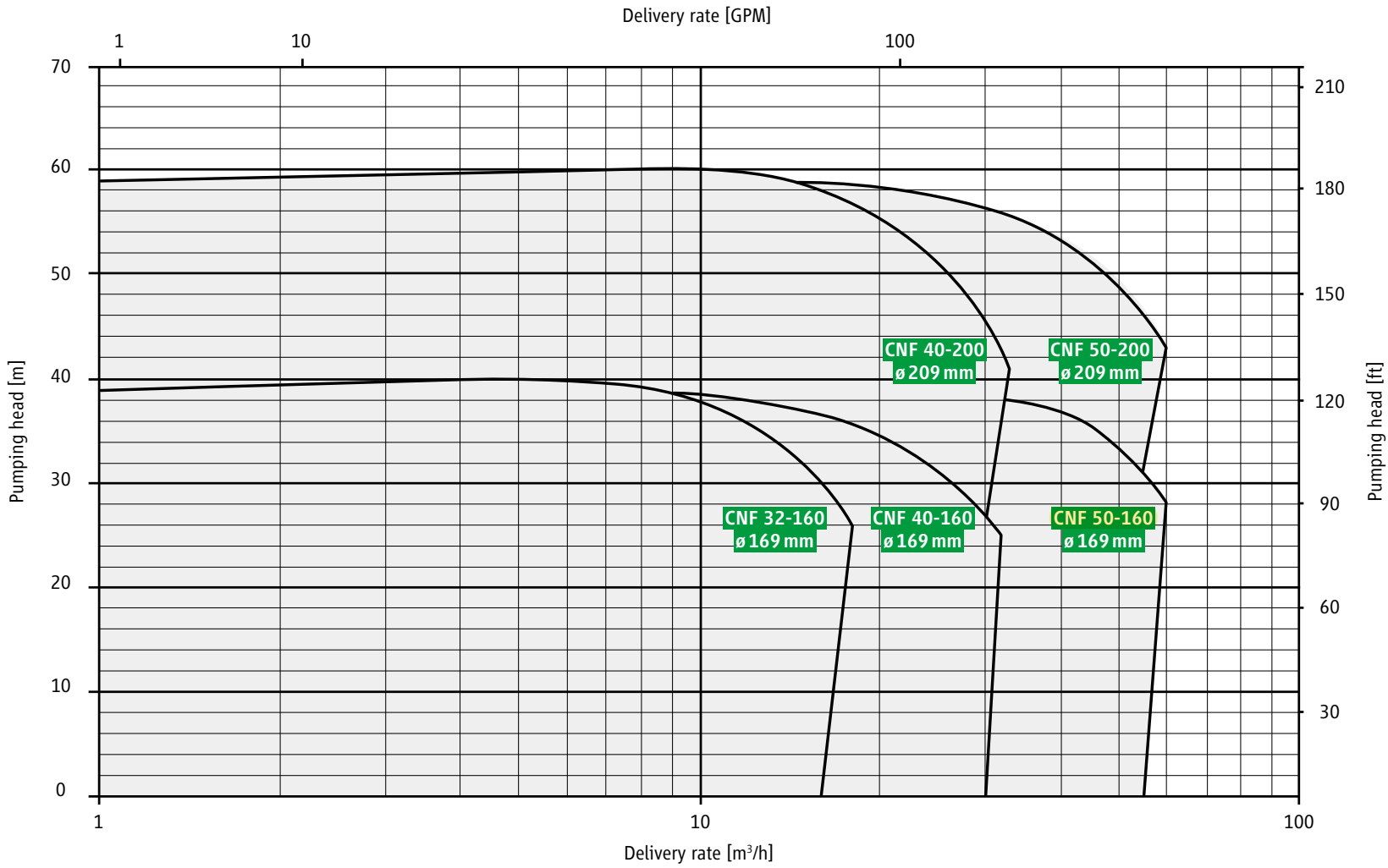

- Table of Contents
- General information
- Function
- Operating principle
- Characteristic maps**
- Versions
- List of parts
- Collective measurements
- Documentation and tests
- Installation
- Protection and monitoring
- Flow regulation
- Design software
- Contact



3500 rpm 60 Hz

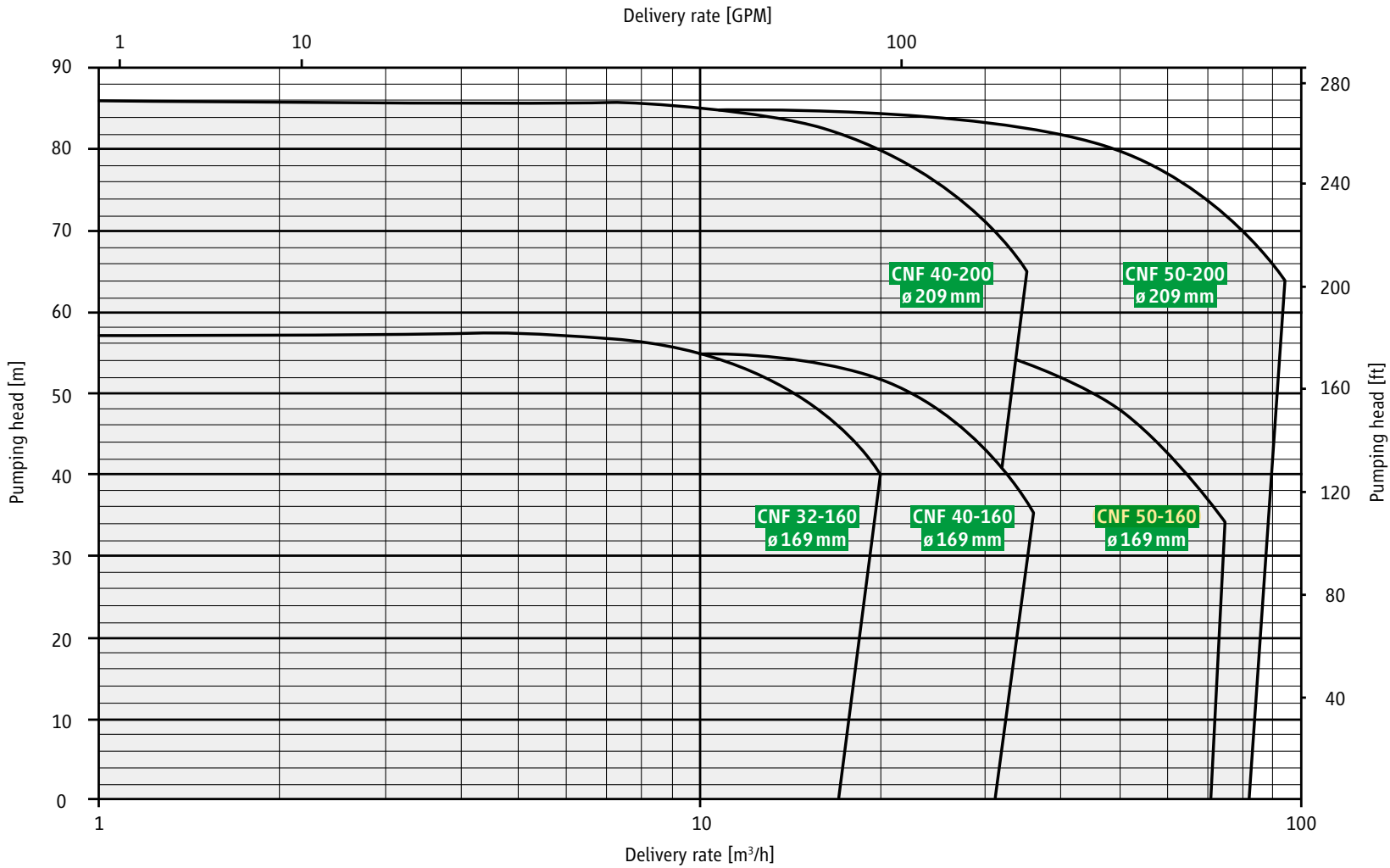

- Table of Contents
- General information
- Function
- Operating principle
- Characteristic maps**
- Versions
- List of parts
- Collective measurements
- Documentation and tests
- Installation
- Protection and monitoring
- Flow regulation
- Design software
- Contact



Versions CNF

Type	Motor	Pump data		Motor data 50 Hz / 60 Hz		Weight kg	PN
		Q _{min.} m ³ /h	Q _{max.} m ³ /h	Output kW [P2]	Rated current at 400 V/480 V		
CNF 32 – 160	AGX 3.0	3.0	20.0	3.0/3.4	7.1	55.0	40
	AGX 4.5	3.0	20.0	4.5/5.6	10.4	63.0	40
CNF 40 – 160	AGX 3.0	4.0	26.0	3.0/3.4	7.1	58.0	40
	AGX 4.5	4.0	26.0	4.5/5.6	10.4	66.0	40
	AGX 6.5	4.0	26.0	6.5/7.4	15.2	69.0	40
	AGX 8.5	4.0	26.0	8.5/9.2	19.0	80.0	40
CNF 40 – 200	AGX 4.5	4.0	26.0	4.5/5.6	10.4	74.0	40
	AGX 6.5	4.0	26.0	6.5/7.4	15.2	77.0	40
	AGX 8.5	4.0	26.0	8.5/9.2	19.0	90.0	40
	CKPx 12.0	6.0	26.0	13.5/15.7	31.0	122.0	25
CNF 50 – 160	AGX 4.5	8.0	60.0	4.5/5.6	10.4	77.0	40
	AGX 6.5	8.0	60.0	6.5/7.4	15.2	80.0	40
	AGX 8.5	8.0	60.0	8.5/9.2	19.0	91.0	40
	CKPx 12.0	8.0	60.0	13.5/15.7	31.0	118.0	25
CNF 50 – 200	AGX 6.5	8.0	60.0	6.5/7.4	15.2	82.0	40
	AGX 8.5	8.0	60.0	8.5/9.2	19.0	96.0	40
	CKPx 12.0	8.0	60.0	13.5/15.7	31.0	125.0	25

Table of Contents

General information

Function

Operating principle

Characteristic maps

Versions

List of parts

Collective measurements

Documentation and tests

Installation

Protection and monitoring

Flow regulation

Design software

Contact



Materials / pressure stages / flanges

Housing	JS 1025
Impeller	JL 1040
Slide bearing	1.4021 / carbon
Shaft	1.4021
Rotor lining	1.4571
Seals	AFM 34*
Pressure rating	PN 40**
Flanges	according to DIN EN 1092-1, PN 40 type D

* asbestos-free aramid fibre, ** test pressure 60 bar

Noise expectancy values

Motors	AGX 3.0	AGX 4.5	AGX 6.5	AGX 8.5	CKPx 12.0
Output power [P2 at 50 Hz]	3.0 kW	4.5 kW	6.5 kW	8.5 kW	13.5 kW
max. expected sound pressure level dB(A) at 50 Hz	52	54	56	57	59
Output power [P2 at 60 Hz]	3.4 kW	5.6 kW	7.5 kW	9.7 kW	15.7 kW
max. expected sound pressure level dB(A) at 60 Hz	52	55	56	57	59

[Table of Contents](#)

[General information](#)

[Function](#)

[Operating principle](#)

[Characteristic maps](#)

Versions

[List of parts](#)

[Collective measurements](#)

[Documentation and tests](#)

[Installation](#)

[Protection and monitoring](#)

[Flow regulation](#)

[Design software](#)

[Contact](#)



List of parts **CNF**

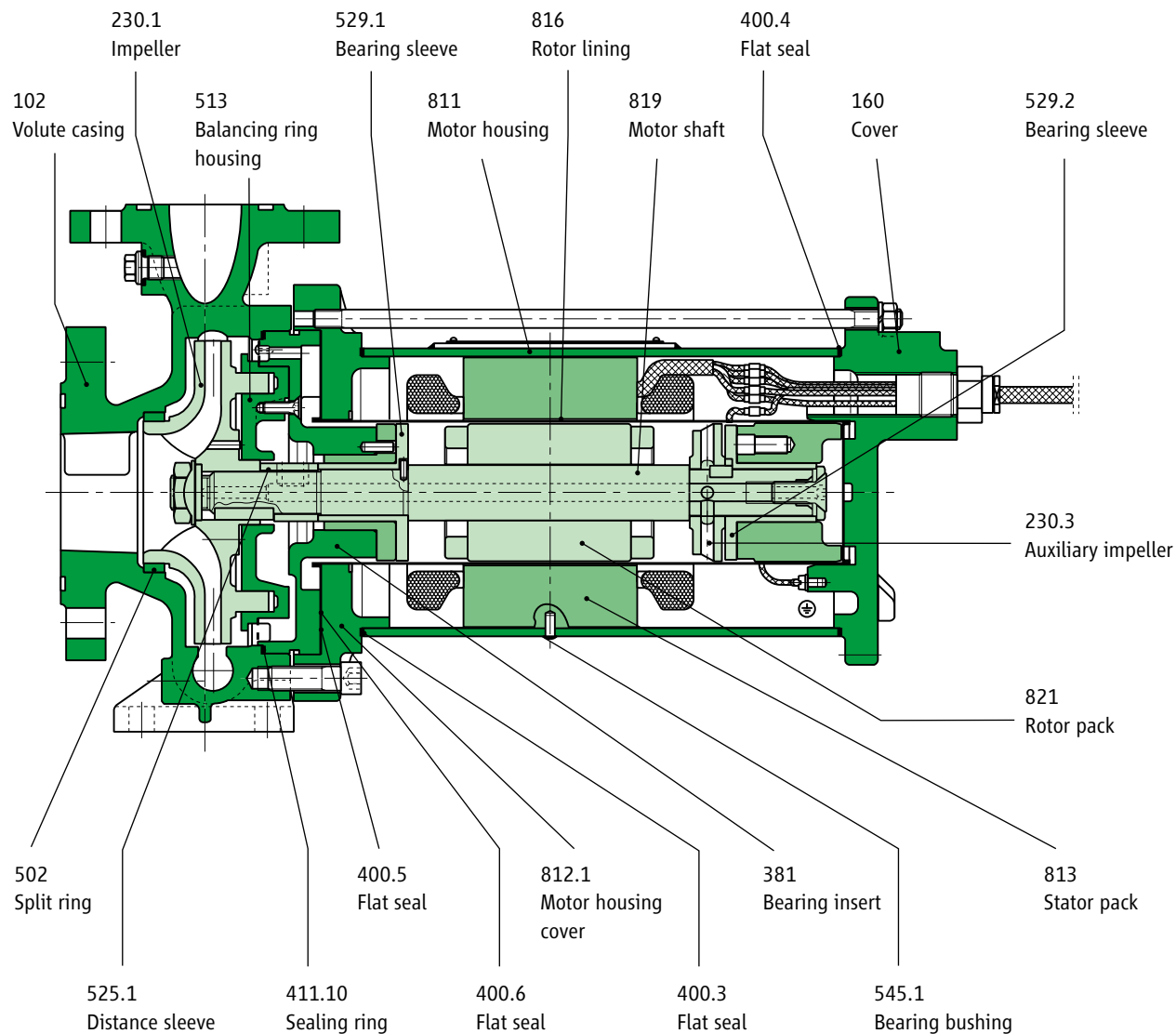

- Table of Contents
- General information
- Function
- Operating principle
- Characteristic maps
- Versions
- List of parts**
- Collective measurements
- Documentation and tests
- Installation
- Protection and monitoring
- Flow regulation
- Design software
- Contact



Dimension drawings

Dimension drawing for motors of size:
AGX 3.0 / AGX 4.5 / AGX 6.5

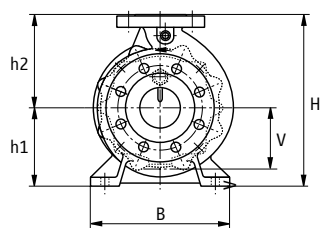
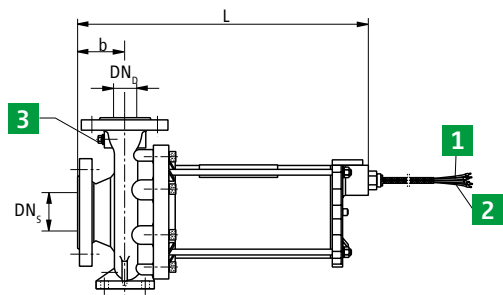

- 1 Cable U1, V1, W1 + protective conductor
AGX 3.0: 4 x 1.5 mm²
AGX 4.5: 4 x 2.5 mm²
AGX 6.5: 4 x 4 mm²
- 2 Cable for PTC thermistor 2 x 1.0 mm²,
Cable 5 + 6, cable length 2.5 m
- 3 Pressure gauge connection G 1/4

Dimension drawing for motors of size:
AGX 8.5 / CKPx 12.0

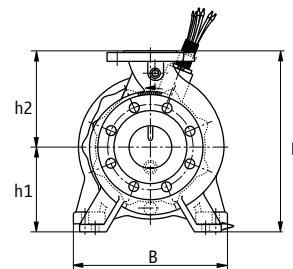
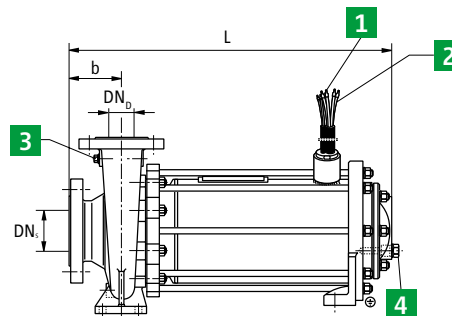

- 1 Cable U1, V1, W1 + protective conductor ⊕
4 x 6 mm², cable length 2.5 m
- 2 Cable for PTC thermistor 2 x 1.0 mm²,
Cable 5 + 6, cable length 2.5 m
- 3 Pressure gauge connection G 1/4
- 4 Connection for temperature sensor
closed with screw plug DIN 912, G 1/2

Table of Contents

General information

Function

Operating principle

Characteristic maps

Versions

List of parts

Collective measurements

Documentation and tests

Installation

Protection and monitoring

Flow regulation

Design software

Contact



Versions CNF

Dimen- sions	CNF 32 – 160	CNF 40 – 160	CNF 40 – 160	CNF 40 – 200	CNF 40 – 200	CNF 50 – 160	CNF 50 – 160	CNF 50 – 200	CNF 50 – 200
	AGX 3.0/4.5	AGX 3.0/4.5/6.5	AGX 8.5	AGX 4.5/6.5	AGX/CKPx 8.5/12.0	AGX 4.5/6.5	AGX/CKPx 8.5/12.0	AGX 6.5	AGX/CKPx 8.5/12.0
Length / L	506	506	575	526	595/620	526	595/620	526	595/620
Width / W	240	240	240	265	265/290	265	265/290	265	265/290
Height / H	292	292	292	340	340	340	340	360	360
h1	132	132	132	160	160	160	160w	160	160
h2	160	160	160	180	180	180	180	200	200
b	80	80	80	100	100	100	100	100	100
v	100	100	100	115	115	108	108	118	118
DN _s	50	65	65	65	65	80	80	80	80
DN _b	32	40	40	40	40	50	50	50	50

Table of Contents

General information

Function

Operating principle

Characteristic maps

Versions

List of parts

Collective measurements

Documentation and tests

Installation

Protection and monitoring

Flow regulation

Design software

Contact



Documentation and tests

Documentation according to HERMETIC Standard consisting of:

Operating manual for the HERMETIC pump

Technical specifications

Characteristic curve of the pump

Sectional drawing

Bills of materials

Dimensional drawing

Cable connection diagram

Plain bearing play

EU Declaration of Conformity

Warranty

30 months from delivery

Standard tests

Hydrostatic pressure test with 1.5x nominal pressure

Balancing of shaft and impeller according to DIN ISO 1940, 6.3

Leak test of the complete pump

Functional test (optionally with protocol)

Additional test

Factory certificate according to EN 10204 / 3.1 for pressurised parts in contact with medium (chemical analysis)

Factory certificate according to EN 10204 / 3.1 for counter flanges

Factory certificate according to EN 10204 / 2.2 for impeller and pump shaft

EUR.1 movement certificate (after examination)

RMRS / DNV / Hapag Lloyd

Table of Contents

General information

Function

Operating principle

Characteristic maps

Versions

List of parts

Collective measurements

Documentation and tests

Installation

Protection and monitoring

Flow regulation

Design software

Contact



SERIES INFORMATION

Contact

sales-support@hermetic-pumpen.com

www.hermetic-pumpen.com

Table of Contents

General information

Function

Operating principle

Characteristic maps

Versions

List of parts

Collective measurements

Documentation and tests

Installation

Protection and monitoring

Flow regulation

Design software

Contact

